

[CONTRIBUTION FROM THE CHEMICAL LABORATORY OF THE UNIVERSITY OF CALIFORNIA]

## The Photostationary States of Some Geometrically Isomeric Acids

BY A. R. OLSON AND F. LYTH HUDSON<sup>1</sup>

Over twenty years ago, Stoermer<sup>1a</sup> showed that many pairs of stereoisomers yield equilibrium mixtures on illumination with ultraviolet light. He showed further that in such a photochemical equilibrium the less stable form was present in the larger amount, thus proving that light does not act merely as a catalyst in hastening thermal equilibrium. The photostationary state of maleic-fumaric acids was studied in greater detail by Kailan.<sup>2</sup> Using a quartz mercury arc without filters, he found that the steady state (about 75% maleic acid) was slightly affected by concentration, but was not affected by the substitution of glass for quartz containers. This reaction was studied further by Warburg,<sup>3</sup> who measured the quantum efficiencies of light at the wave lengths 2070, 2530 and 2820 Å. Vaidya<sup>4</sup> extended the range to 3130 Å., and in addition determined the quantum efficiencies of light of this wave length for producing inversion of citraconic, *o*-coumaric, cinnamic and isocinnamic acids. Stoermer had found that solutions of mesaconic acid in methyl alcohol are scarcely changed into citraconic acid on illumination. Vaidya quotes this result, but does not say whether or not he tested it in aqueous solution.

Olson,<sup>5</sup> in a theoretical paper, treated stationary states of this kind with the aid of potential energy diagrams. Figures 1 and 2 are taken from this paper. Figure 1 represents a plot of the potential energy of a molecule against the angle  $\varphi$ , through which one-half of a molecule is twisted relative to the other about the double bond as axis, starting with  $\varphi = 0$  for the *cis* molecule. The lower curve is the type to be expected for an unexcited molecule. It is assumed that excitation removes an electron to such a distance that the effect of the double bond disappears. The upper curve is, then, the simplest type to be expected for an excited molecule. The height of the top above the trough of this curve is, then, the heat of the transition, when one molecule changes into the other. The shape of these curves is not known from experimental data, but for the purpose of this discussion of a simple case it was assumed that the upper curve had the equation

$$V = A - k \sin^2 (\varphi/2)$$

With the above assumption regarding the potential in the upper state, the Schrodinger equation reduces to the Mathieu equation, for which

(1) Commonwealth Fellow, University of California.

(1a) Stoermer, *Ber.*, **44**, 637 (1911).

(2) Kailan, *Z. physik. Chem.*, **87**, 333 (1914).

(3) Warburg, *Sitzb. preuss. Akad. Wiss., Physik.-math. Klasse*, **33**, 960 (1919).

(4) Vaidya, *Proc. Roy. Soc. (London)*, [A] **129**, 299 (1930).

(5) Olson, *Trans. Faraday Soc.*, **27**, 69 (1931).

solutions are known. One may then calculate the  $\psi$  function for a level such as  $B''B''$  in the upper state. If this is done, it is found that the

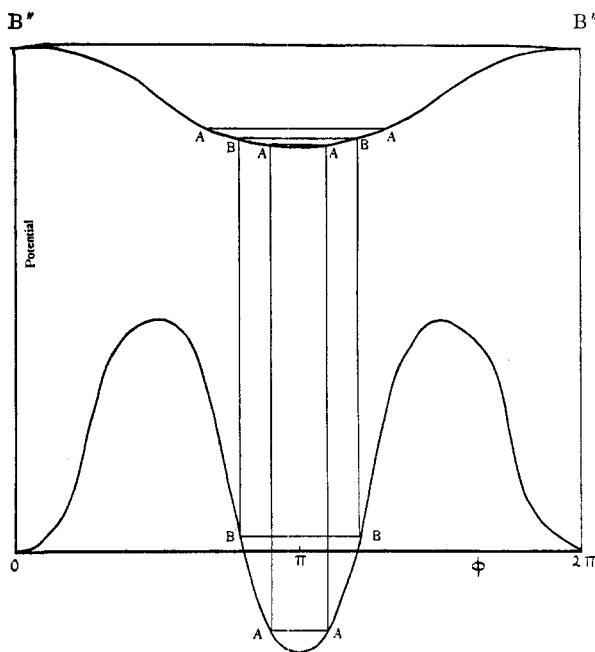

Fig. 1.

probability (as measured by  $\psi^2$ ) of finding the molecule in the upper state between the angles  $-\pi/2, \pi/2$  is very much greater than that of finding it between  $\pi/2, 3\pi/2$ ; that is, it is in the *cis* state for the greater part of the

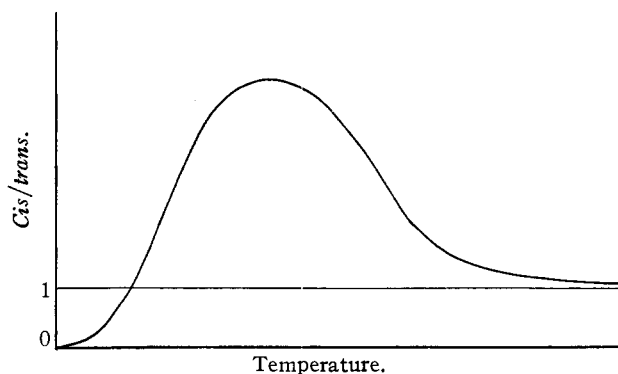

Fig. 2.

time. If this is repeated for various energy levels, one obtains a graph such as Fig. 2 for the ratio of *cis* to *trans* to be expected at the stationary

state at various temperatures. The same result is obtained, whether one considers the problem from the point of view of the Schroedinger equation for a torsional vibrator, or from that of a mechanical model. Thus, mechanically, this means that the fraction of the total time that a pendulum is in the region of high potential energy increases with the amplitude of the swing until the pendulum can make a complete revolution. If the energy of the pendulum is increased still further, the ratio of the velocity of the pendulum in the upper half of the revolution to that in the lower half of the revolution approaches unity and therefore the ratio of the times spent in these two configurations approaches unity. In this article no account was taken of differences in absorption coefficients of the two isomers, and so the conclusions applied only if the absorption coefficients were equal.

We shall now discuss a quantity which will replace the ratio of the concentrations in cases where the coefficients are not equal. Consider a thin slice  $dx$  of solutions of *cis* and *trans* acids, whose molecular absorption coefficients and concentrations are, respectively,  $\alpha_1$ ,  $\alpha_2$ ,  $C_1$ ,  $C_2$ . Suppose the slice is illuminated in the direction of  $x$  by monochromatic light of intensity  $J$  quanta per second over the area of the slice. We will define  $p$  as the mean probability that a molecule of either kind, which has absorbed a quantum, will return to the *cis* state on deactivation. Then  $1 - p$  is the probability that it will return to the *trans* state.

For this case Beer's law may be written

$$-\frac{1}{J} \cdot \frac{dJ}{dx} = \alpha_1 \cdot C_1 + \alpha_2 \cdot C_2$$

The number of quanta absorbed in this slice is

$$-dJ = J(\alpha_1 \cdot C_1 + \alpha_2 \cdot C_2) dx$$

The number returning to the *cis* state per second will be

$$pJ(\alpha_1 \cdot C_1 + \alpha_2 \cdot C_2) dx$$

At the steady state, this must be equal to the number of *cis* molecules absorbing in one second, which is

$$\begin{aligned} J \cdot \alpha_1 \cdot C_1 dx &= pJ(\alpha_1 \cdot C_1 + \alpha_2 \cdot C_2) dx \\ \alpha_1 \cdot C_1 &= p(\alpha_1 \cdot C_1 + \alpha_2 \cdot C_2) \end{aligned}$$

Similarly for the *trans* molecules

$$\begin{aligned} \alpha_2 \cdot C_2 &= (1 - p)(\alpha_1 \cdot C_1 + \alpha_2 \cdot C_2) \\ \frac{p}{1 - p} &= \frac{\alpha_1 \cdot C_1}{\alpha_2 \cdot C_2} \end{aligned}$$

Further, suppose the quantum efficiencies of the two acids, expressed as molecules isomerized per quantum absorbed, are  $\Theta_1$ ,  $\Theta_2$ . There will be formed per second  $\Theta_1 \cdot J \cdot \alpha_1 \cdot C_1 \cdot dx$  molecules of *trans* from *cis* and  $\Theta_2 \cdot J \cdot \alpha_2 \cdot C_2 \cdot dx$  molecules of *cis* acid from *trans*. At the steady state these must be equal.

$$\frac{\Theta_2}{\Theta_1} = \frac{\alpha_1 \cdot C_1}{\alpha_2 \cdot C_2} = \frac{p}{1 - p}$$

The above equations define  $p$  in terms of experimental quantities and make no assumptions as to what actually happens in the upper state. We may now replace  $C_1/C_2$  in Olson's paper by  $p/(1-p)$  and apply the argument to isomers, whatever the ratio of the absorption coefficients may be.

Both  $\alpha_1/\alpha_2$  and  $p/(1-p)$  may vary with wave length, so it is desirable that monochromatic light should be used. If continuous radiation is used, light of some frequencies may be almost completely absorbed in a very short distance (the first 0.1 mm.), while other frequencies will get farther into the solution. Thus, if there is no diffusion, one may well get a different photostationary composition in each layer. The actual result obtained will vary with the size and shape of the containing vessel and the time of exposure. Thus, a photostationary state measured with general illumination is devoid of any meaning. In the case of fumaric and maleic acids the absorption coefficients are nearly equal over the whole spectrum, so that here  $p/(1-p) = C_1/C_2$ , and this difficulty does not arise. This probably explains why Kailan<sup>2</sup> obtained the same photostationary state in quartz and glass vessels. In the other cases investigated,  $\alpha_1/\alpha_2$  varies rapidly with wave length, so filters were used to get the nearest possible approach to monochromatic light.

### Experimental

**Preparation of Materials.**—The less stable of two stereoisomeric acids is usually much more soluble in common solvents than the more stable; hence, it is unreliable to purify maleic, citraconic, or *cis*-cinnamic acid merely by crystallization. Maleic acid, for example, is about a hundred times as soluble in water as fumaric, so repeated recrystallization from water will produce a product containing one per cent. of fumaric acid.

Fumaric acid from the laboratory supplies was purified by three crystallizations from hot water. The product melted at 285° in a sealed tube. Maleic acid was purified by a method due to Terry and Eichelberger. It melted at 134.5°. As the value given in the literature is 131°, the acid was again converted into the anhydride and the process repeated. It still melted at 134.5°, which appears to be the correct melting point. Vaidya<sup>4</sup> also gives 134° as the melting point of his acid.

Ordinary *trans*-cinnamic acid was recrystallized from hot water and melted at 133.4°. *Cis*-cinnamic acid was made by a method due to Stoermer.<sup>6</sup> The acid melted sharply at 58.3°. A second preparation melted at 67.8°. According to Beilstein's "Handbuch der organischen Chemie," there are three different crystalline forms of *cis*-cinnamic acids, melting at 42, 58 and 68°. The last is the most stable, but all three are considered to be the same in solution.

Kahlbaum's citraconic and mesaconic acids were used. They were purified in the same way as fumaric and maleic acids, except that the citraconic anhydride could not be crystallized and was distilled instead.

**Conductivity Measurements.**—In the cases examined  $M/200$  solutions of the *cis* acids have conductivities about twice as great as the corresponding solutions of the *trans* acids. Mixed solutions are therefore readily analyzed by means of their conductivities. This method has been used by other investigators. The cell was kept in a water thermostat and connected to the rest of the circuit by twelve-foot leads, which

(6) Stoermer, *Ber.*, **42**, 4865 (1909).

were shielded. With this circuit, a change in resistance of 4 parts in 10,000 could readily be measured.

Two Pyrex conductivity cells were used, each holding about 6 cc. of solution and having platinum black electrodes about 1 cm. square and 0.5 cm. apart. To facilitate filling and emptying, two tubes were sealed on, provided with glass stoppers and bent in the same way as those on the absorption cell F, Fig. 3. The cells were standardized by means of decimolar potassium chloride, made up according to the method of Parker and Parker,<sup>7</sup> whose value for the specific conductivity was used. This was not an essential part of the method, but was done so that the conductivities of the solutions might be compared with published values.

The solutions were to be used at different temperatures, so that a definition of concentration by volume was undesirable. They were therefore made up by weight, directly in the Jena glass bottles in which they were kept. Conductivity water, distilled from alkaline permanganate, was used.

Table I gives the values obtained for the molecular conductivities compared with those of other authors. For this the solutions were assumed to be 0.005 molar; the error produced by this is less than that of the uncalibrated instruments.

TABLE I  
MOLECULAR CONDUCTIVITIES

| Acid        | Molarity | Molecular conductivities |                     |                      |                                 |                              |                       |
|-------------|----------|--------------------------|---------------------|----------------------|---------------------------------|------------------------------|-----------------------|
|             |          | Obs.                     | Vaidya <sup>4</sup> | Ostwald <sup>8</sup> | Rivett<br>Sidgwick <sup>9</sup> | White<br>Jones <sup>10</sup> | Bjerrum <sup>11</sup> |
| Fumaric     | 0.005    | 136                      | 136                 | 134                  |                                 |                              |                       |
| Maleic      | .005     | 294                      | 287                 | 288                  | 288                             |                              |                       |
| Mesaconic   | .005     | 122                      | 126                 | 123.5                |                                 | 117                          |                       |
| Citraconic  | .005     | 211                      | 214                 | 208                  | 204                             | 222                          |                       |
| T.-cinnamic | .003     | 39.6                     | 39.7                | 39                   |                                 |                              |                       |
| C.-cinnamic | .003     | 72.8                     | 74                  |                      |                                 |                              | 72.5                  |

Except for Vaidya's results, which were for the same concentrations as those used by us, the above figures were obtained by graphical interpolation.

**Measurement of Photostationary States.**—The quantum efficiencies of the isomeric changes are low (see Table VIII), so it is not desirable to start with a pure acid and illuminate it until it reaches a steady state. The steady state is found by making up a mixture close to it in composition, filling a conductivity cell with part of it and illuminating part. The change in the bridge reading on illumination may then be found. The quartz illumination cell held about 2 cc. more than the conductivity cells, so one of the latter could be filled with the exposed solution. The mixtures were made up from the stock solutions by means of calibrated burets. The change in bridge reading was plotted against the composition of the solution; when about three points were obtained on each side of zero change, a mean curve was drawn through them, the point of zero change giving the composition at the photostationary state.

Volmar<sup>12</sup> has stated that maleic, fumaric, citraconic and mesaconic acids are de-

(7) Parker and Parker, *THIS JOURNAL*, **46**, 312 (1924).

(8) Ostwald, *Z. physik. Chem.*, **3**, 369 (1889).

(9) Rivett and Sidgwick, *J. Chem. Soc.*, **97**, 1677 (1910).

(10) White and Jones, *Am. Chem. J.*, **44**, 175 (1910).

(11) Bjerrum, *Ber.*, **43**, 571 (1910).

(12) Volmar, *Compt. rend.*, **181**, 467 (1924).

composed by light with the evolution of carbon dioxide and the formation of acids of the acrylic acid series. This is denied by Vaidya.<sup>4</sup> Oxalic, formic, lactic and several other acids are decomposed in a similar way, according to Pierce and Morey.<sup>13</sup> It was desirable, therefore, to see whether any such reaction took place to an extent sufficient to interfere with determinations of the photostationary states. Mixtures of approximately the same compositions as the photostationary mixtures were exposed at 90° for two hours to the unfiltered mercury arc radiation. After cooling, 5 cc. of the solution was titrated with *m*/200 baryta water in a current of carbon dioxide-free air. No measurable change was detected for any of the acids used. Thus, any actual change must be less than 1% for this exposure, or less than 0.25% for half an hour's exposure, which was usually used in determinations. This method would not show any reaction involving no change in the total acid concentration.

**Source of Light, Filters, etc.**—A Cooper-Hewitt mercury arc was used in all experiments. To get the greatest possible intensity, it was backed by a bright aluminum reflector, calculated to bring the light to an approximate focus at the quartz cell.

Two filters were used: a chlorine filter for the 2536 Å. line, and a potassium chromate one for the two lines near 3130 Å. The chlorine filter has been described by Oldenberg.<sup>14</sup> A stout quartz bulb, 5.5 cm. in diameter, was sealed onto a graduated Pyrex tube, into which some liquid chlorine was distilled while it was cooled in liquid air. The system was then evacuated and sealed off, and spectrograms taken with the chlorine at various pressures, controlled by altering the temperature of the graduated tube. Four and one-half atmospheres was chosen as the best pressure. The seal was broken and chlorine was distilled off until enough of the liquid remained to produce this pressure in the bulb. The chlorine was then condensed in the bulb, the air pumped off and the bulb sealed. As the vessel was not optically plane, it was not possible to determine its transmission experimentally, but this may be calculated approximately from the results of von Halban and Siedentopf.<sup>15</sup> In the course of some measurements of absorption coefficients, to be described later, spectrograms of the mercury arc were taken with screens of different transmissions. From these the relative intensities of the unfiltered 2650 and 2536 groups of lines were approximately computed as 1:1.9. These two lines are transmitted by the chlorine to the extent of 10 and 64%, respectively. By multiplying the two ratios, we find the effective light transmitted by the filter is 92% of 2536 and 8% of 2650. The only other light transmitted appreciably has a wave length greater than 4000 and no photochemical effect. These figures are very approximate, as the absorption of the irregular quartz surfaces is not taken into account. Also the photographic effect of this light is not uniform.

In the neighborhood of 3100 Å. the effect of light on a photographic plate is fairly uniform for different wave lengths. The transmission of the potassium chromate filter (made of 2.5 cm. of *m*/2000 K<sub>2</sub>CrO<sub>4</sub>) and the intensities of the lines transmitted are given in Table II. They were determined by absorption measurements and may be taken as accurate within 5%.

TABLE II

|   |      |      |      |      |
|---|------|------|------|------|
| Lines.....                                    | 3341 | 3130 | 3020 | 2967 |
| Relative intensities.....                     | 0.18 | 1.74 | 0.49 | 0.29 |
| Percentage of line transmitted by filter..... | 6.0  | 43.7 | 21.6 | 6.0  |
| Relative amounts of energy transmitted.....   | 1.2  | 85   | 11.9 | 1.9  |

The arrangement used for the chlorine filter is shown in Fig. 3. The chlorine in the bulb A is fitted into a Bakelite tube B, with rubber washers above and below. The side

(13) Pierce and Morey, *THIS JOURNAL*, **54**, 467 (1932).

(14) Oldenberg, *Z. Physik*, **29**, 328 (1924).

(15) Von Halban and Siedentopf, *Z. physik. Chem.*, **108**, 80 (1922).

tube on the bulb projects through a slot in B. The lower end of B is closed by a plane quartz window D, which is clamped down tightly onto a rubber washer by the Bakelite flange E. E is held on by nuts on three threaded brass rods (not shown in the figure), screwed tightly into B. The circular quartz cell F is 0.5 cm. thick and holds 8 cc. It is held, for convenience, between two brass flanges G, connected together with three screws. They have holes bored to fit the brass rods projecting from E, and are slipped over these and screwed on with wing nuts, so that the cell is about half a cm. below D. When a weakly absorbing solution was being used, F was backed by an aluminum reflector, so as to double its effective length. The upper part of B has a flange resting on a metal support, by means of which the filter and cell are hung in a thermostat, so that cooling air could be circulated around A when runs were made above room temperature. Water was convenient for use in the thermostat, as it transmits ultraviolet light. At temperatures above 60° it required continuous replenishing to balance evaporation.

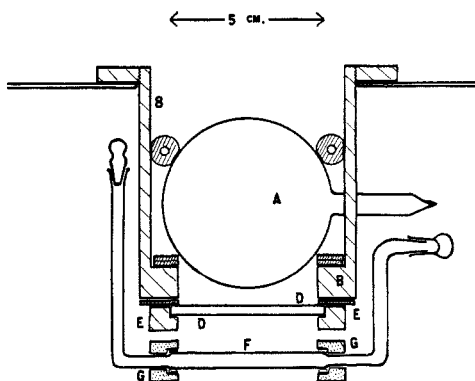

Fig. 3.

with the potassium chromate filter, but are approximate only to one or two per cent. Maleic and fumaric acids were investigated without any filters.

**The Measurement of Absorption Coefficients.**—The absorption coefficients were measured by a photographic method which Mr. N. S. Bayliss has been using in this Laboratory in connection with another problem. Since the details of the method are to be published soon, it will suffice to note that by this method the accurate results of Halban and Siedentopf on the absorption by chlorine were checked within 2%.

The values obtained for the extinction coefficients are given in Tables III and IV. It will be observed that the values of the ratio  $\epsilon_{cis}/\epsilon_{trans}$  vary less than the values of the coefficients themselves. This may be due to the very rapid change of  $\epsilon$  with wave length, which rises as much as 1% per Ångström unit. A small change in the setting of the microphotometer is then liable to cause a large change in the value obtained for  $\epsilon$ . The starred values in the tables were obtained from extrapolations on the blackening curves, and are not reliable.

**Results for Photostationary States.**—0.005 *M* solutions were used for maleic, fumaric, citraconic and mesaconic acids, and 0.003 *M* solutions for the two cinnamic acids. In the last case, readings could not be taken below 15°, as the *trans*-cinnamic acid crystallized. For fumaric and

When the potassium chromate filter was used, it was contained in a vessel similar to F, but 2.5 cm. thick. This was hung above F from the top of the thermostat by means of a wire frame. The box containing the mercury arc was brought immediately above the top of the thermostat. The temperature was controlled to one-tenth of a degree by a toluene-mercury regulator.

Cinnamic acids have fairly high quantum efficiencies and readily gave results with both filters. With the other acids, however, the change was very slow. Results with citraconic and mesaconic acids were obtained

TABLE III  
 EXTINCTION COEFFICIENTS

| Maleic, Fumaric, Citraconic, Mesaconic Acids                |                 |                 |         |                        |                     |   |  |
|---|-----------------|-----------------|---------|------------------------|---------------------|---|--|
| Plate   | Wave length, Å. | Thick-ness, cm. | Acid    | Concn., mole per liter | Log $\frac{J_0}{J}$ | $\epsilon$                                | $\frac{\epsilon_{cis}}{\epsilon_{trans}}$      |
| 9   | 3130            | 5.46            | mal.    | 0.01022                | 0.410               | 7.41                                      | 0.954  |
|   |                 |                 | fum.    | .00996                 | 0.418               | 7.69                                      |  |
| 9   | 3020            | 5.46            | mal.    | .01022                 | 1.08                | 19.4                                      | 0.84*  |
|   |                 |                 | fum.    | .00996                 | 1.25*               | 23*                                       |  |
| 10  | 3130            | 6.99            | mal.    | .01022                 | 0.504               | 7.05                                      | 1.02   |
|   |                 |                 | fum.    | .00996                 | .482                | 6.90                                      |  |
| 11  | 3130            | 8.49            | mal.    | .01022                 | .653                | 7.52                                      | 1.004  |
|   |                 |                 | fum.    | .00996                 | .635                | 7.30                                      |  |
| 19  | 3130            | 9.00            | mal.    | .00991                 | .716                | 8.02                                      | 0.974  |
|   |                 |                 | fum.    | .00999                 | .739                | 8.23                                      |  |
| 18  | 3020            | 2.96            | mal.    | .00991                 | .568                | 19.4                                      | .93  |
|   |                 |                 | fum.    | .00999                 | .618                | 20.9                                      |  |
| 18  | 3020            | 2.96            | citrac. | .05303                 | .464                | 2.95                                      | .215   |
|   |                 |                 | mesac.  | .02022                 | .818                | 13.7                                      |  |
| 9   | 3020            | 5.46            | citrac. | .05303                 | .850                | 2.93                                      | .25*   |
|   |                 |                 | mesac.  | .01995                 | 1.3*                | 12*                                       |  |
| 9   | 3130            | 5.46            | citrac. | .05303                 | 0.291*              | 1.01*                                     | .287*  |
|   |                 |                 | mesac.  | .01995                 | .382                | 3.51                                      |  |
| 10  | 3130            | 6.99            | citrac. | .05303                 | .353                | 0.952                                     | .289   |
|   |                 |                 | mesac.  | .01995                 | .459                | 3.29                                      |  |
| 11  | 3130            | 8.49            | citrac. | .05303                 | .448                | 0.994                                     | .287   |
|   |                 |                 | mesac.  | .01995                 | .588                | 3.47                                      |  |
| 19  | 3130            | 9.00            | citrac. | .05303                 | .494                | 1.035                                     | .308   |
|   |                 |                 | mesac.  | .02022                 | .606                | 3.36                                      |  |
| The accompanying values of the ratio were taken as averages |                 |                 |         |                        | Wave length         | $\frac{\epsilon_{mal.}}{\epsilon_{fum.}}$ | $\frac{\epsilon_{citrac.}}{\epsilon_{mesac.}}$ |
|   |                 |                 |         |                        | 3130                | 1   | 0.29   |
|   |                 |                 |         |                        | 3020                | 0.93                                      | 0.22   |

maleic acids, unfiltered light was used and the ratio of the absorption coefficients was taken as unity for the purpose of calculating transition probabilities. The results obtained for the ratio  $\epsilon_1/\epsilon_2$  were very near unity for the wave lengths used.

Some explanation is required for the methods of calculation used in the other cases. We showed that there is no such thing as a definite, steady state when monochromatic light is not used. In our case filters were used, giving about 90% monochromatic light. Some allowance has to be made for the effect of the other 10%, and this cannot be calculated accurately. We showed that the effective light transmitted through the potassium chromate filter was 85% of 3130 Å. and 12% of 3020, neglecting the other two components. One centimeter of a 50% mixture of the citra-



TABLE IV  
EXTINCTION COEFFICIENTS  
*Cis*- and *Trans*-cinnamic Acids

| Plate | Wave length, Å. | Thick-ness, cm. | Acid         | Concn., mole per liter | Log $\frac{J_0}{J}$ | $\epsilon$ | $\frac{\epsilon_{cis}}{\epsilon_{trans}}$ |
|-------|-----------------|-----------------|--------------|------------------------|---------------------|------------|---|
| 13    | 3130            | 8.98            | <i>cis</i>   | 0.0003                 | 0.956               | 353        | 0.421*                                    |
|       |                 |                 | <i>trans</i> | .00015                 | 1.136*              | 844*       |   |
| 14    | 3130            | 2.50            | <i>cis</i>   | .0003                  | 0.284               | 379        | .395                                      |
|       |                 |                 | <i>trans</i> | .00015                 | .360                | 960        |   |
| 16    | 3130            | 5.90            | <i>cis</i>   | .0003                  | .659                | 372        | .382                                      |
|       |                 |                 | <i>trans</i> | .00015                 | .862                | 974        |   |
| 19    | 3130            | 9.00            | <i>cis</i>   | .00024                 | .737                | 341        | .395*                                     |
|       |                 |                 | <i>trans</i> | .00015                 | 1.166*              | 864*       |   |
| 18    | 3020            | 2.96            | <i>cis</i>   | .0003                  | 0.932               | 1050       | .242                                      |
|       |                 |                 | <i>trans</i> | .00006                 | .769                | 4330       |   |
| 17    | 3020            | 1.62            | <i>cis</i>   | .0003                  | .543                | 1115       | .206                                      |
|       |                 |                 | <i>trans</i> | .00015                 | 1.32                | 5420       |   |
| 14    | 3020            | 2.50            | <i>cis</i>   | .0003                  | 0.828               | 1104       | .207*                                     |
|       |                 |                 | <i>trans</i> | .00015                 | 2*                  | 5340*      |   |
| 15    | 2536            | 8.69            | <i>cis</i>   | .000006                | 0.564               | 10860      | .832                                      |
|       |                 |                 | <i>trans</i> | .000006                | .678                | 13050      |   |
| 13    | 2536            | 8.98            | <i>cis</i>   | .000006                | .572                | 10620      | .841                                      |
|       |                 |                 | <i>trans</i> | .000006                | .680                | 12620      |   |
| 15    | 2650            | 8.69            | <i>cis</i>   | .000006                | .445                | 8580       | .454                                      |
|       |                 |                 | <i>trans</i> | .000006                | .980                | 18870      |   |
| 13    | 2650            | 8.98            | <i>cis</i>   | .000006                | .438                | 8130       | .460                                      |
|       |                 |                 | <i>trans</i> | .000006                | .952                | 17660      |   |

The accompanying values of the ratio were taken as averages

| Wave length | $\frac{\epsilon_{cis}}{\epsilon_{trans}}$ |
|-------------|---|
| 3130        | 0.39                                      |
| 3020        | .22                                       |
| 2650        | .45                                       |
| 2536        | .83                                       |

conic and mesaconic solutions used will absorb 2.5% of the 3130 light and 4.1% of the 3020. The relative amounts of light actually absorbed are obtained by multiplying these by the relative strengths of the two lines above. These relative amounts come out to 3.5 and 1, respectively. The ratios of the extinction coefficients  $\epsilon_1/\epsilon_2$  were 0.22 for 3020 and 0.29 for 3130. The effective value will be somewhere between these two, and for a reasonable mean we take

$$\frac{\epsilon_1}{\epsilon_2} = \frac{3.5 \times 0.29 + 1 \times 0.22}{4.5} = 0.27$$

A similar method was used for calculating a mean value of  $\epsilon_1/\epsilon_2$  for cinnamic acids, only in this case it was sufficient to assume that absorption was complete. The relative strengths of the two lines concerned are therefore used directly.

Thus, for the potassium chromate filter

$$\frac{\epsilon_1}{\epsilon_2} = \frac{85 \times 0.39 + 12 \times 0.22}{97} = 0.36$$

and for the chlorine filter

$$\frac{\epsilon_1}{\epsilon_2} = \frac{92 \times 0.837 + 8 \times 0.457}{100} = 0.807$$

The photostationary compositions and the probability ratios are summarized in Tables V, VI and VII, and are plotted in Figs. 4 and 5.

TABLE V  
PHOTOSTATIONARY CONCENTRATIONS OF MALEIC AND FUMARIC ACIDS  
Unfiltered Radiation

| Temp., °C. | Percentage maleic | Percentage fumaric | Maleic Fumaric | $\frac{p}{1-p}$ |
|------------|-------------------|--------------------|----------------|-----------------|
| 0          | 71.4              | 28.6               | 2.49           | 2.49            |
| 10         | 71.4              | 28.6               | 2.49           | 2.49            |
| 30         | 69.3              | 30.7               | 2.26           | 2.26            |
| 60         | 69.3              | 30.7               | 2.26           | 2.26            |
| 90         | 69.6              | 30.4               | 2.29           | 2.29            |

TABLE VI  
PHOTOSTATIONARY CONCENTRATIONS OF CITRACONIC AND MESAONIC ACIDS  
Potassium Chromate Filter

| Temp., °C. | Percentage citraconic | Percentage mesaconic | Citraconic Mesaconic | $\frac{p}{1-p}$ |
|------------|-----------------------|----------------------|----------------------|-----------------|
| 0          | 69                    | 31                   | 2.2                  | 0.59            |
| 25         | 53                    | 47                   | 1.1                  | .30             |
| 50         | 48                    | 52                   | 0.92                 | .25             |
| 90         | 46                    | 54                   | .85                  | .23             |

TABLE VII  
PHOTOSTATIONARY CONCENTRATIONS OF *Cis*- AND *Trans*-CINNAMIC ACIDS  
Potassium Chromate Filter

| Temp., °C. | Percentage <i>cis</i> | Percentage <i>trans</i> | $\frac{cis}{trans}$ | $\frac{p}{1-p}$ |
|------------|-----------------------|-------------------------|---------------------|-----------------|
| 15         | 77.0                  | 23.0                    | 3.55                | 1.21            |
| 50         | 77.3                  | 22.7                    | 3.40                | 1.22            |
| 90         | 77.1                  | 22.9                    | 3.37                | 1.21            |

Chlorine Filter

|    |      |      |      |      |
|----|------|------|------|------|
| 15 | 54.2 | 45.8 | 1.18 | 0.95 |
| 50 | 54.2 | 45.8 | 1.18 | .95  |
| 70 | 57.0 | 43.0 | 1.33 | 1.07 |
| 80 | 60.0 | 40.0 | 1.50 | 1.21 |
| 90 | 64.0 | 36.0 | 1.77 | 1.43 |

Some quantum efficiencies from the results of Warburg<sup>3</sup> and Vaidya<sup>4</sup> are given in Table VIII. Some of the values of  $p/(1-p)$  in the last column are calculated by comparing results from solutions of different concentrations and are not strictly valid.

**The Energy Changes Involved in Isomerization.**—The energy change involved in the isomerization of an acid in dilute solution may be calculated

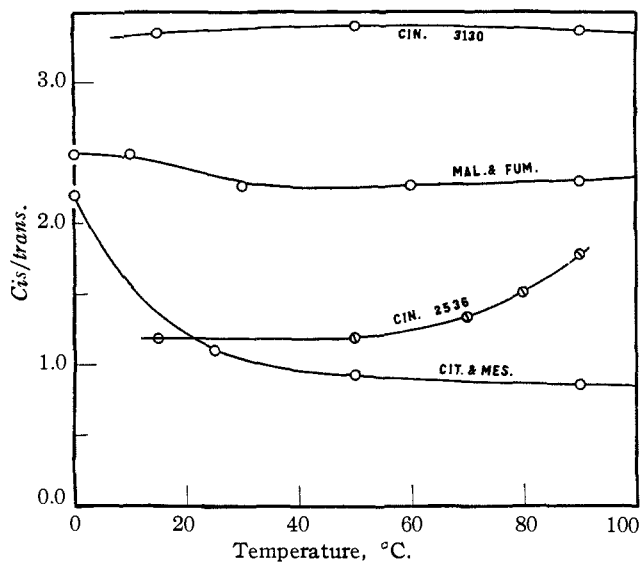

Fig. 4.

from the heats of combustion and heats of solution. Not only do differences between four quantities, two of them large, come in so that the final result may easily be in error by as much as 1000 calories, but the hydration

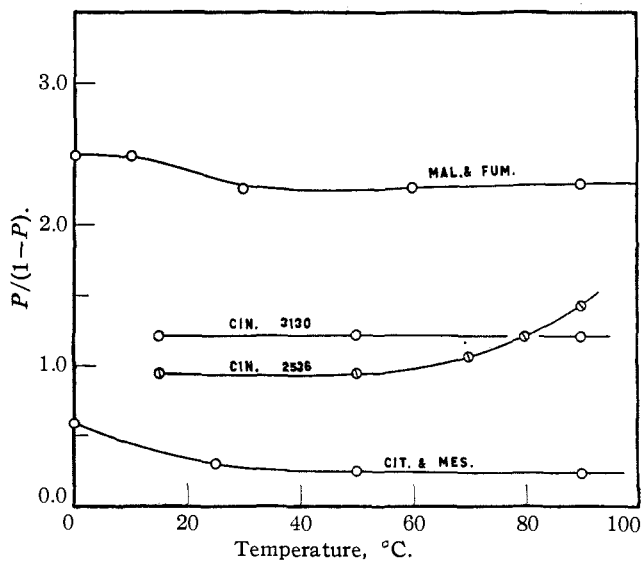

Fig. 5.

TABLE VIII  
 QUANTUM EFFICIENCIES FROM OTHER SOURCES

| Wave length | Concn. of acid. (cis) maleic |            | Concn. of acid. (trans) fumaric |            | $\frac{p}{1-p} = \frac{\gamma_2}{\gamma_1}$ | Author |
|-------------|------------------------------|------------|---------------------------------|------------|---|--------|
|             | $\gamma_1$                   | $\gamma_2$ | $\gamma_1$                      | $\gamma_2$ |   |        |
| 2070        | 0.0102                       | 0.0314     | 0.0102                          | 0.102      | 3.25  | W.     |
|             | .00514                       | .0358      | .00306                          | .0764      | 2.14  | W.     |
| 2530        | .0102                        | .0414      | .0102                           | .0961      | 2.32  | W.     |
|             | .00514                       | .0462      | .00306                          | .0829      | 1.80  | W.     |
| 2820        | .0102                        | .0297      | .0102                           | .1291      | 4.35  | W.     |
|             | .00514                       | .0308      | .00306                          | .0983      | 3.06  | W.     |
| 3130        | .010                         | .048       | .01                             | .118       | 2.46  | V.     |
|             | .005                         | .0525      | .005                            | .083       | 1.58  | V.     |
| Mean value  |                              |            |                                 |            | 2.62  |        |
| 3130        | <i>Cis-cin.</i><br>0.003     | 0.206      | <i>Tr.-cin.</i><br>0.003        | 0.61       | 2.96  | V.     |

energies may be changed on activation so that in the citraconic-mesaconic case we do not know which isomer is the more stable. Thus  $\Delta H$  in solution for the reaction *cis*  $\rightarrow$  *trans* is  $-400$  cal. for this case. For maleic  $\rightarrow$  fumaric acid it is about  $-5000$  cal.

Another datum of interest is the activation energy of maleic acid which Höjendahl<sup>16</sup> gives as 15,800 calories. This value was obtained from the rate of thermal isomerization, and was checked by the absorption spectrum of molten maleic acid. This will give us some idea of the order of magnitude of activation energy to be expected in solution.

 TABLE IX  
 THERMOCHEMICAL DATA (CALORIES)

| Source<br>Author   | Heats of combustion<br>for acid = CO <sub>2</sub> + H <sub>2</sub> O |                                 |                        | Mean heats<br>of isom-<br>erization<br>(solids)<br>$\Delta H$ for<br><i>cis</i> $\rightarrow$ <i>trans</i> | Heats of<br>solution<br>$\Delta H$ for<br>acid (aq.) | Heats of<br>isom-<br>erization<br>(solution)<br>$\Delta H$ for<br><i>cis</i> $\rightarrow$ <i>trans</i> |
|--------------------|--|---------------------------------|------------------------|--|--|---|
|                    | Beilstein<br>Luginin   | Beilstein<br>Stohman and Kleber | $\Delta H$             |  |  |   |
| Citraconic         | $\Delta E$<br>-483,522   | $\Delta E$<br>-480,000          | $\Delta H$<br>-479,700 |  | +2800  |   |
| Mesaconic          | -479,100   | -477,500                        | -477,200               |  | +5500  |   |
| Diff.              | - 4,422  | - 2,500                         | - 2,500                | -3100  | -2700  | - 400   |
| Maleic             | $\Delta H$<br>-327,480   | $\Delta H$<br>-326,300          |                        |  | +4444  |   |
| Fumaric            | -319,278   | -320,100                        |                        |  | +5906  |   |
| Diff.              | - 6,202  | - 6,200                         |                        | -6200  | -1462  | -4738   |
| <i>C</i> -cinnamic |  |                                 | -1,047,000             |  |  |   |
| <i>T</i> -cinnamic |  |                                 | -1,041,000             |  |  |   |
| Diff.              |  |                                 | - 6,000                | -6000  |  |   |

(16) Höjendahl, *J. physik. Chem.*, **28**, 758 (1924).

### Discussion

A stationary state with aqueous solutions of mesaconic and citraconic acids has not been reported previously. Stoermer<sup>1</sup> and Vaidya<sup>4</sup> each report no change, but Vaidya seems to have assumed that Stoermer's result for alcoholic solutions would apply to aqueous ones, since he does not describe any experiment to confirm this.

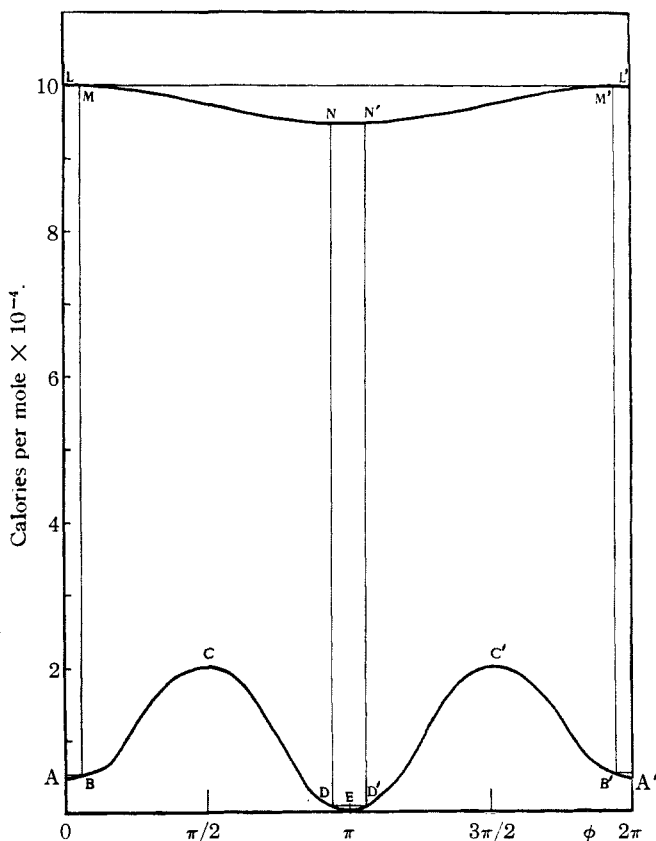

Fig. 6.

The absorption of a quantum of light of wave length 300 will produce an activation of about 95,000 calories per mole. If we assume from Höjendahl's result for the activation energy of maleic acid that 16,000 calories above the normal *cis* state gives the height of the potential energy humps for unactivated acids, then our energy diagram will be like that in Fig. 6. The upper state will be some sort of potential energy curve a long way above the maxima for the lower curve.

We can now discuss possible shapes for this upper curve. At 300°K., the energy per degree of freedom per mole is  $\frac{1}{2} RT$ , or about 300 calories.

Thus, an average *trans* molecule will be oscillating along DD' and a *cis* molecule along B'B in the normal state. When they first reach the upper state, they will therefore be oscillating along NN' and MM', respectively.

Now consider the type of curve in Fig. 7 (i). This is the  $V = A - k_1 \sin^2 \phi / 2$  type, described in the introduction. For cinnamic and fumaric and maleic acids, we may expect AA' to be about 5000 calories above E. The activated *cis* and *trans* molecules will be oscillating along BB' and DD'. The point of temperature equilibrium is only 600 calories above E, very near to DD'; therefore, no activated *trans* molecules at all will be expected to oscillate above CC', which will be necessary if any *cis* is to be formed. This potential curve, then, will not fit in with any of the results.

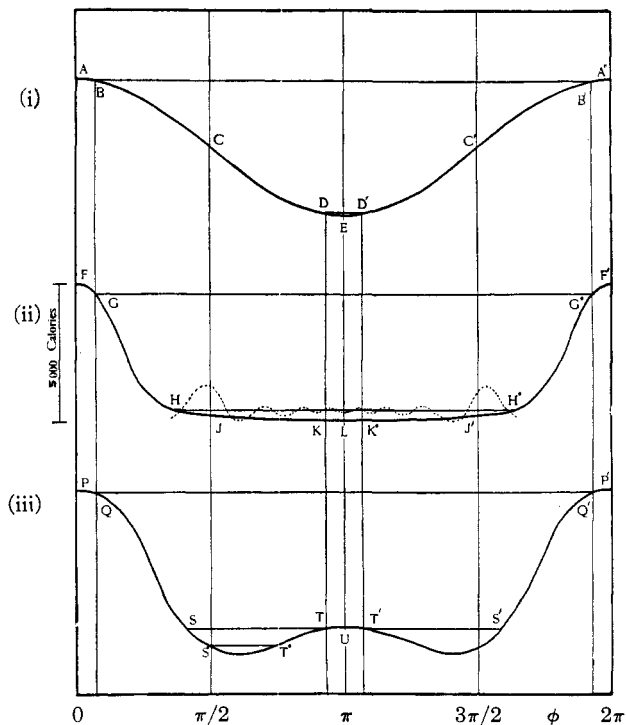

Fig. 7.

Now consider Fig. 7 (ii). On acquiring temperature equilibrium, a molecule will oscillate along HH'. We cannot calculate the  $\psi$  function exactly for such a level; all we know from the Schroedinger equation is that

$$\frac{1}{\psi} \frac{\partial^2 \psi}{\partial \phi^2} = -\frac{8\pi^2 I}{\hbar^2} (E - V)$$

Thus, when  $(E - V)$  is small, *i. e.*, at H and H', either  $\psi$  is large, or its curvature is small. A probable type of curve for  $\psi$  is dotted in. Thus, with a potential curve of this sort, any ratio of *cis* to *trans* may be produced.

depending on the position of  $HH'$  and the steepness of the potential curve. A potential curve of this sort would be expected if the repulsion of the larger groups falls off very rapidly with distance, and if the hydrogen and carboxyl groups (hydrogen and phenyl also in the case of cinnamic acid) exercise no repulsive effect on each other.

If these groups do have steric effects on each other, we shall have a curve of the type in Fig. 7 (iii). There will be two minima, corresponding to configurations which are mirror images, somewhere between the *cis* and *trans* positions. An activated *trans* molecule will vibrate along  $ST$  or  $S'T'$ . Thus, it will be possible for it to change over to *cis* without coming to thermal equilibrium at all.

An activated *cis* molecule, vibrating along  $QQ'$ , will have very little chance of becoming a *trans* molecule on deactivation, unless it loses thermal energy, and vibrates along some path  $S''T''$ . It would do this after a very few collisions, for its energy is so much higher than the average. With this energy curve, then, we may expect any distribution of the two acids, depending on the magnitude of the subsidiary maximum and the positions of the two minima. There does not, then, appear to be much to choose between (ii) and (iii) except that in (ii) we shall require a longer life in the activated state, so that the *trans* molecule may acquire thermal equilibrium. In the case of fumaric and maleic acids, the quantum efficiencies are low, *i. e.*, most molecules return to their original states on deactivation. This suggests that the time of activation is so short that the activated molecules may not have time to reach thermal equilibrium.<sup>17</sup>

BERKELEY, CALIFORNIA

RECEIVED OCTOBER 17, 1932  
PUBLISHED APRIL 6, 1933

---

(17) Just before this article was submitted for publication, my attention was called to a paper by Mulliken [*Phys. Rev.*, **41**, 751 (1932)], in which he concludes that Fig. 7(iii) represents the potential function for the excited molecule. However, he states that I did not consider this possibility in my earlier paper. In that paper I wrote "nor have we been concerned with the more complicated potential functions for the possible motion which we have discussed. Such departures from simple functions doubtless do occur even for the simplest molecules." I wished merely to postpone such considerations until enough experimental data were available to make such a discussion profitable.—A. R. OLSON.